

# PRODUCT SPECIFICATION DRAWING

## QUICK STRAP® #QS-5, #QS-12

### THERMAL EXPANSION TANK MOUNTING BRACKET

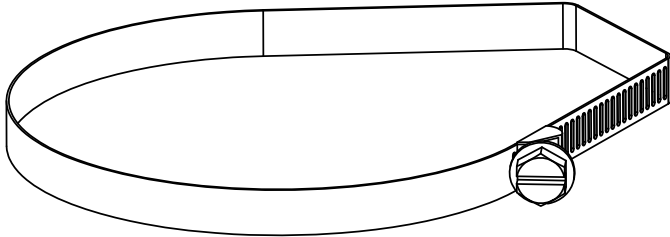

1/2" Wide, .025" Thick, Stainless Steel Band; (2)

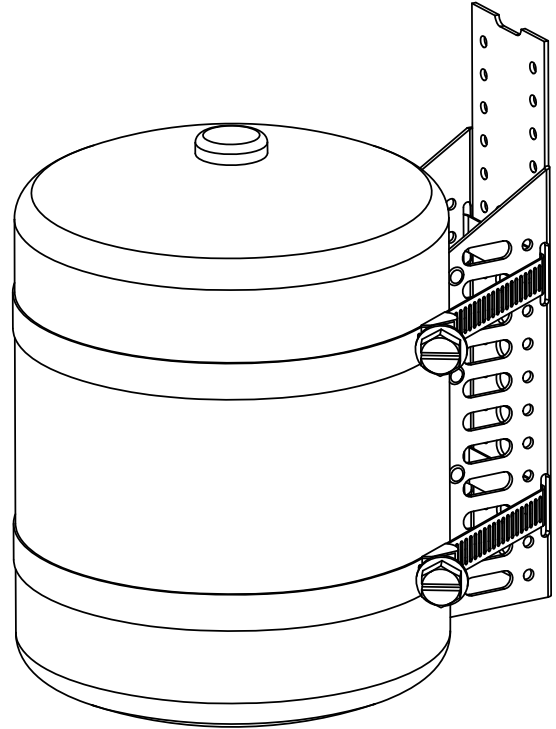

#8 x 1.5" Sheet Metal Screw; (2)

ALL DIMENSIONS IN INCHES

The QUICK STRAP® #QS-5, #Q-12 is a thermal expansion tank mounting bracket. Secures to wall and takes weight and load off pipes. Galvanized and stainless steel construction. Available for 2-5 gallon units. The system includes: Wall Bracket, (2) Straps, and (2) #8 x 1.5" Sheet Metal Screws.

MODEL	SIZE
QS-5	UP TO 2.5 GAL; UP TO 9.0" DIA
QS-12	2.5 TO 5 GAL; 9.5" TO 13" DIA

#### Product Information:

- Material: Strap, 1/2" Wide, .025" Thick, 201/301 Stainless Steel
- Material: Bracket, 16 Gauge Galvanized Steel

THIS INFORMATION IS PROPRIETARY TO HOLDRITE AND IS SUBJECT TO CHANGE WITHOUT NOTICE. IT MAY NOT BE REPRODUCED IN PART OR WHOLE WITHOUT WRITTEN AUTHORIZATION.



CONVERTING MAKESHIFT METHODS INTO ENGINEERED SOLUTIONS<sup>SM</sup>  
 800-321-0316 OR 760-744-6944 / FAX: 760-744-0507 / WWW.HOLDRITE.COM  
 spec\_QS-5\_-12\_RevC

Product Submittal	
Job Name:	
Date:	
Part Number:	Qty:
Architect / Owner:	
Contractor:	
Notes:	